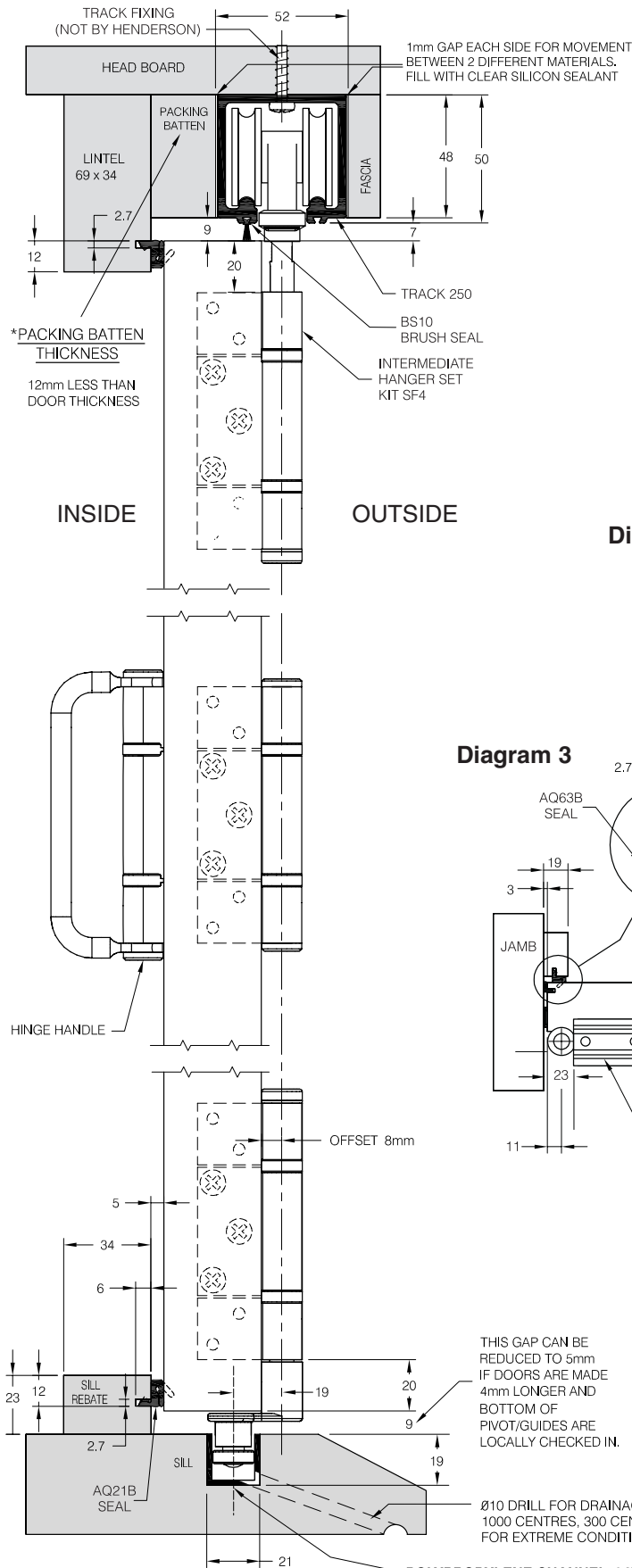


## Fitting Instructions for top hung exterior folding doors

**Diagram 1**

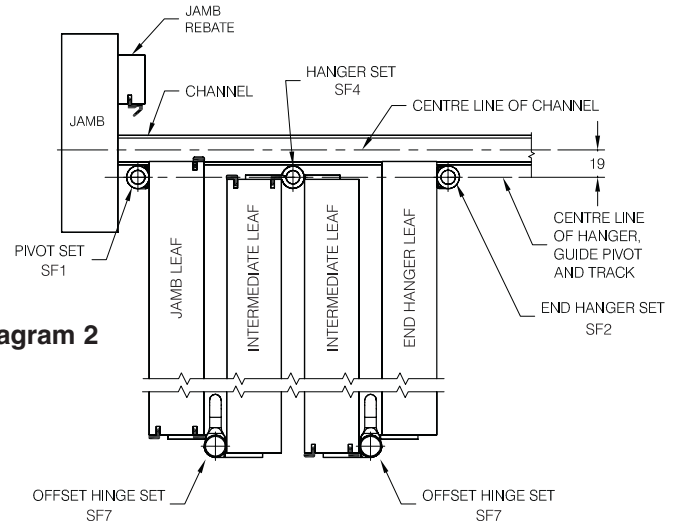


### SYSTEM CAPACITY

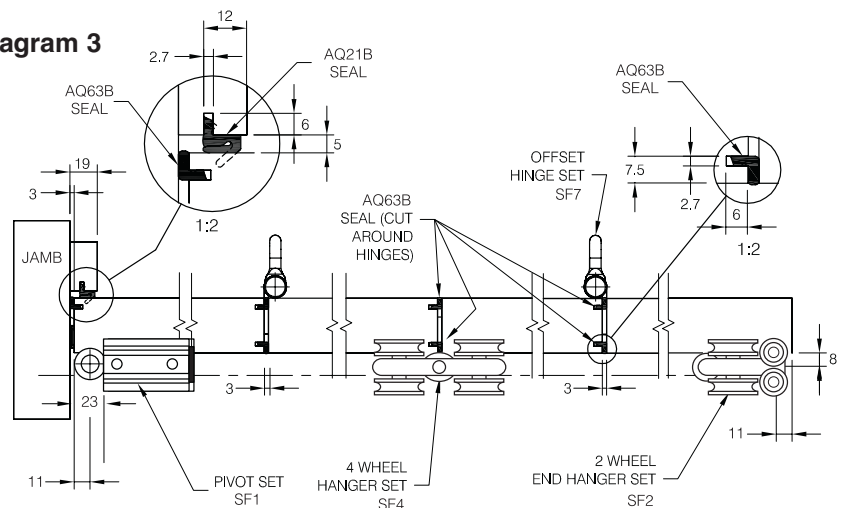
- Maximum leaf height - 3300mm
- Maximum leaf weight - 75kg
- Maximum leaf width - 900mm
- Maximum leaf thickness - 35-67mm

For thicker or thinner doors please contact P C Henderson Technical Department - [technical@pchenderson.com](mailto:technical@pchenderson.com)

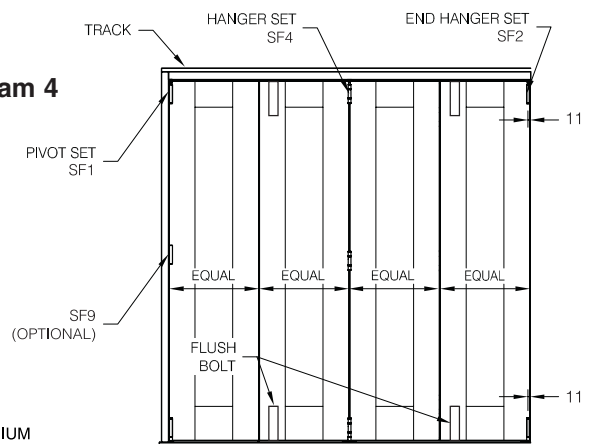
**Diagram 2**



**Diagram 3**



**Diagram 4**

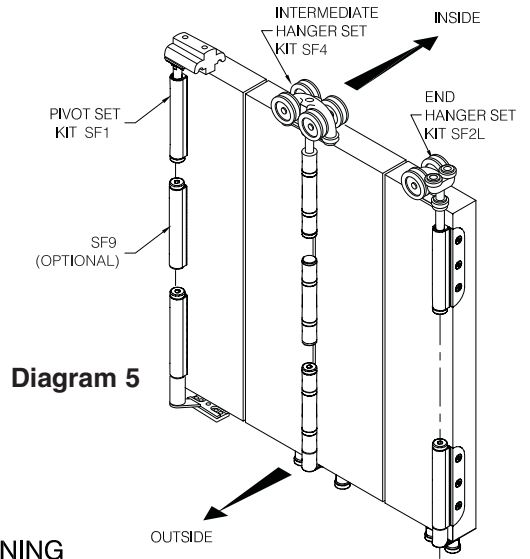


TYPICAL OUTSIDE ELEVATION

**POLYPROPYLENE CHANNEL 94P**  
WHEN USED IN CONJUNCTION WITH ALUMINIUM SUPPORT CHANNEL 94SC THE OUTER CHANNEL DIMENSIONS BECOME 23H x 25W

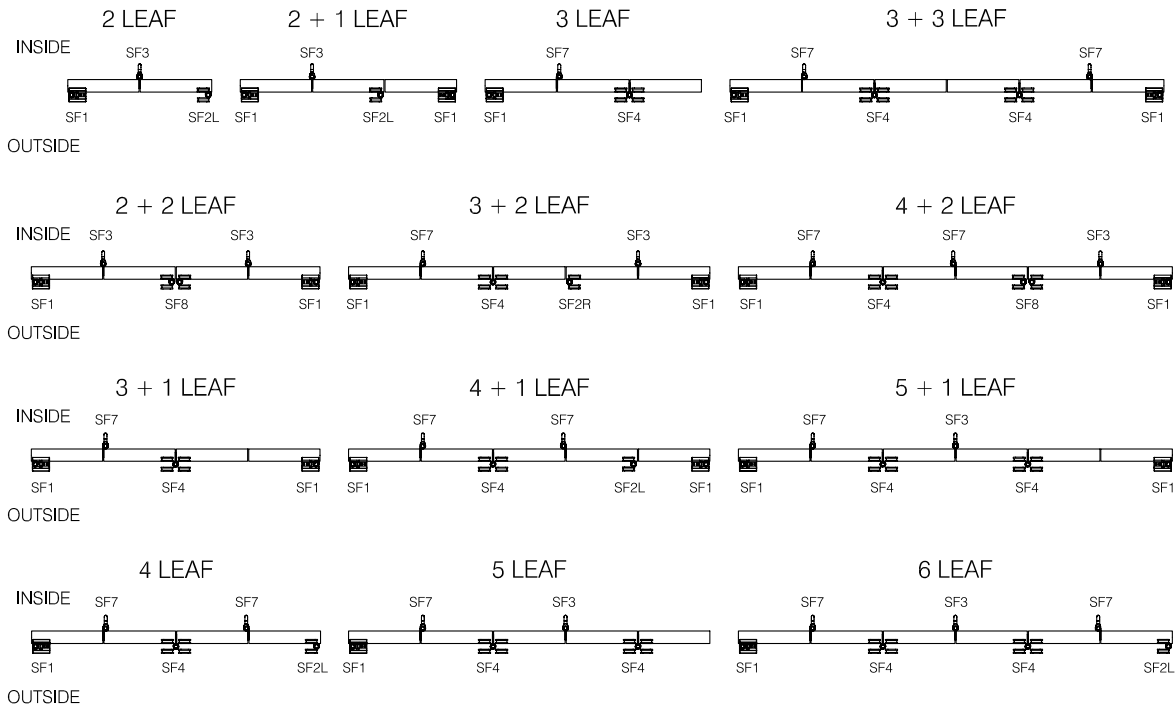
# PREPARATION

- SF1 - Pivot Assembly Set
- SF2R - End Hanger Set Right Hand
- SF2L - End Hanger Set Left Hand
- SF3 - Hinge Set with Handle
- SF4 - Intermediate Hanger Set
- SF5 - Hinge Set Inward Opening
- SF6 - Hinge Set Offset Inward Opening
- SF7 - Hinge Set Offset Outward Opening
- SF8 - Rebated End Hanger Meeting
- SF9 - Pivot Hinge for Doors Over 2200mm High (Optional)
- SF10 - Face Fix Handle (Optional)

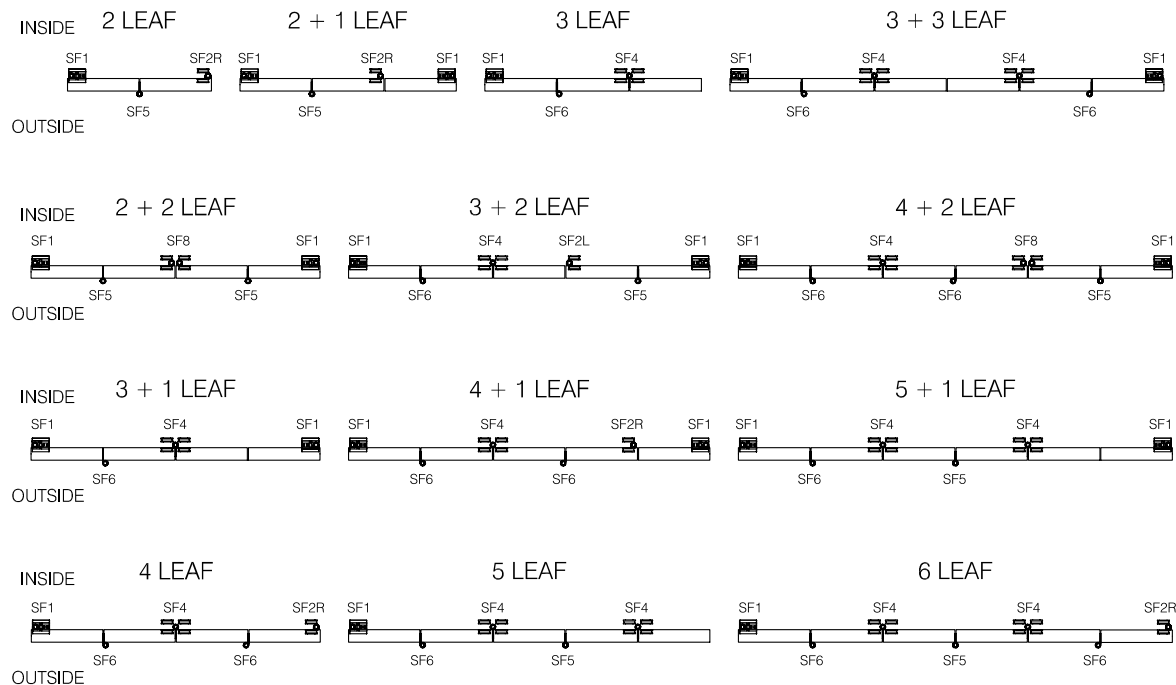


**Diagram 6**

## DOOR HARDWARE - KIT ORIENTATION, OUTWARD OPENING

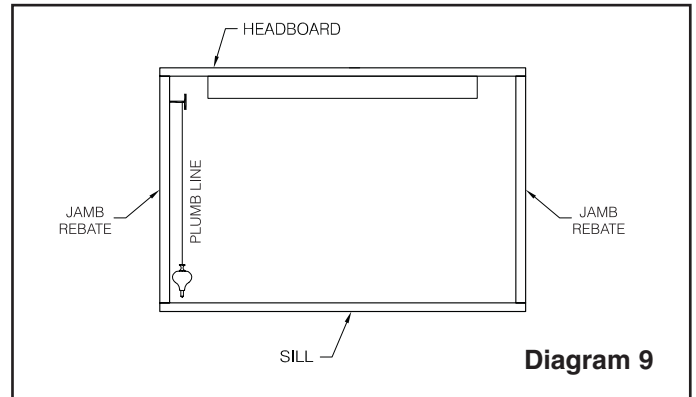
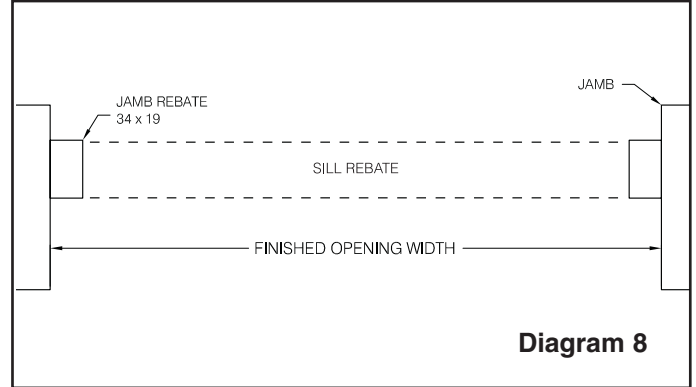
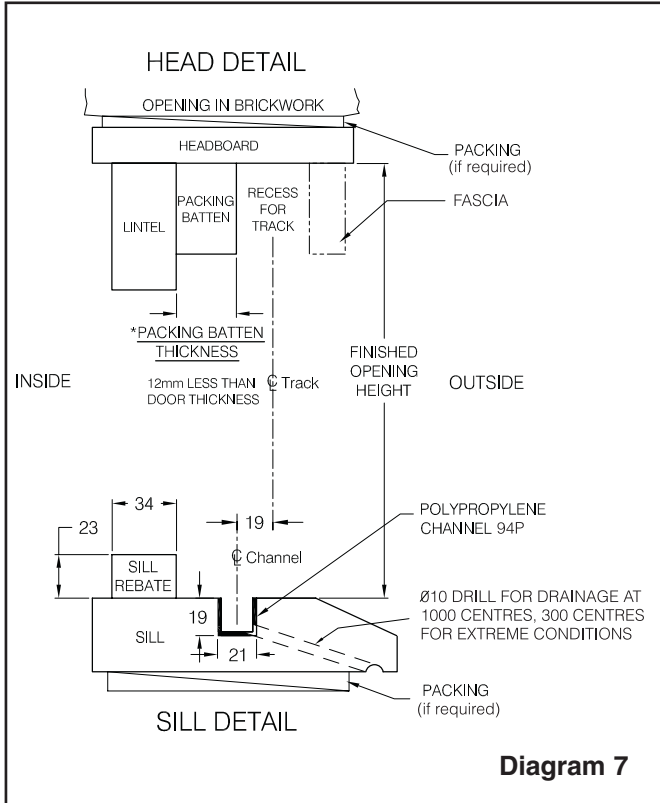


## DOOR HARDWARE - KIT ORIENTATION, INWARD OPENING

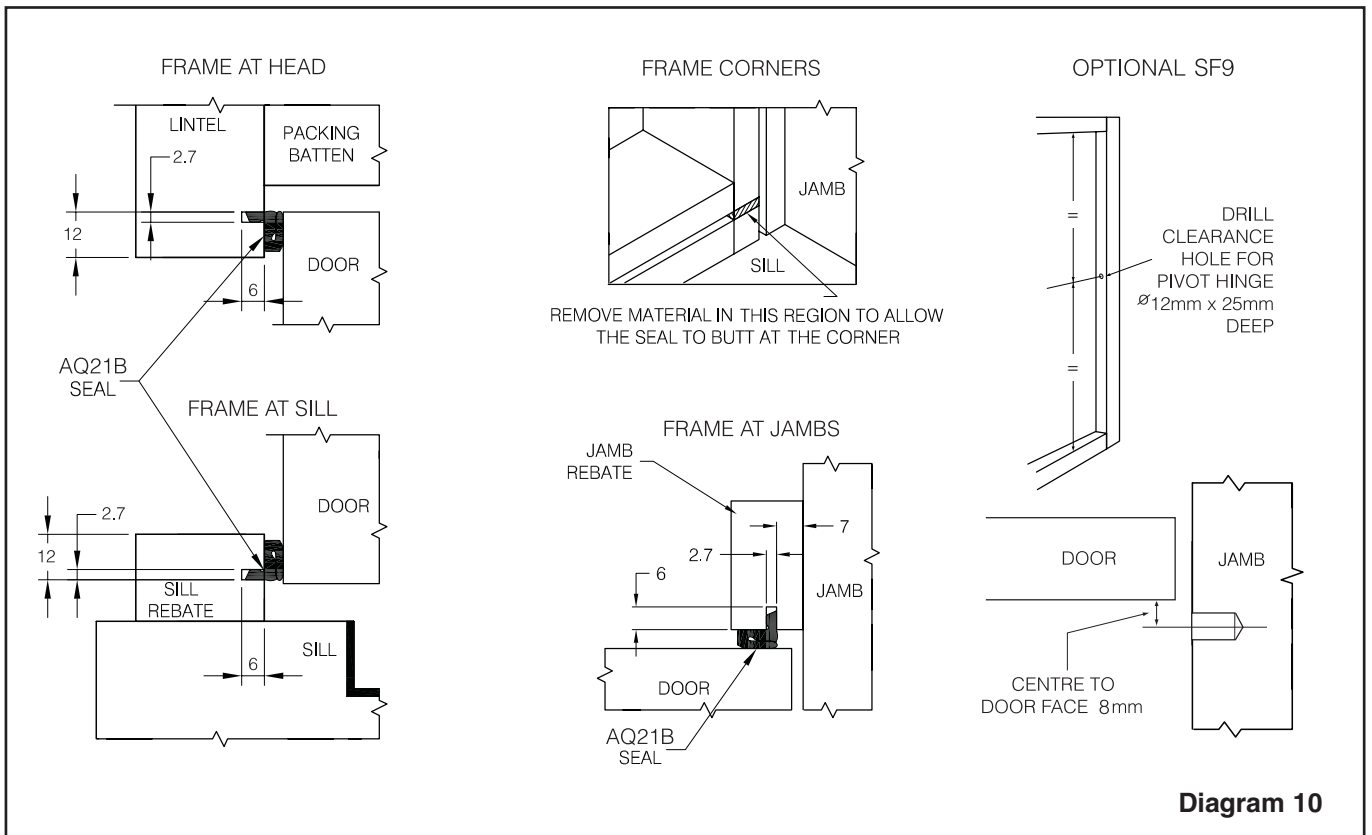


## Preparing the opening

Ensure the opening is square and all load bearing areas are suitable for the weight of the system. Take particular care to ensure there is sufficient strength in the structure above the opening to take the concentrated weight of the doors, when in the open stacked position. The Securefold system provides +/- 3mm of horizontal and vertical adjustment. Use a plumb line to ensure that the centre line of the track and the centre line of the channel are offset by 19mm.



## Preparing the door frame



## Preparing the door leaves

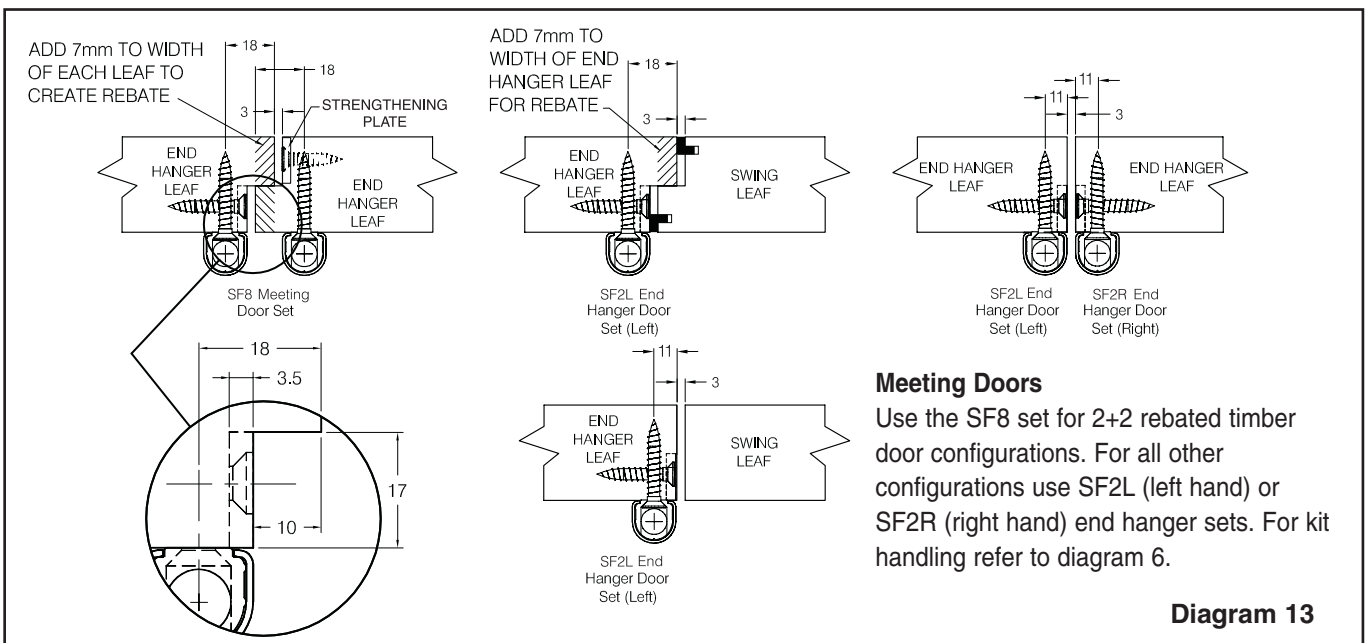
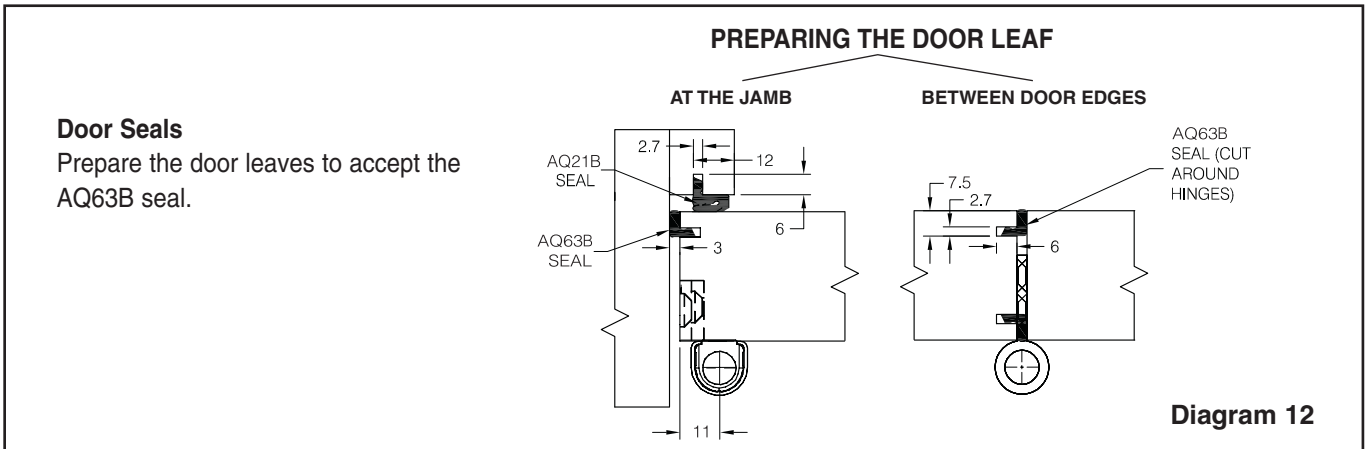
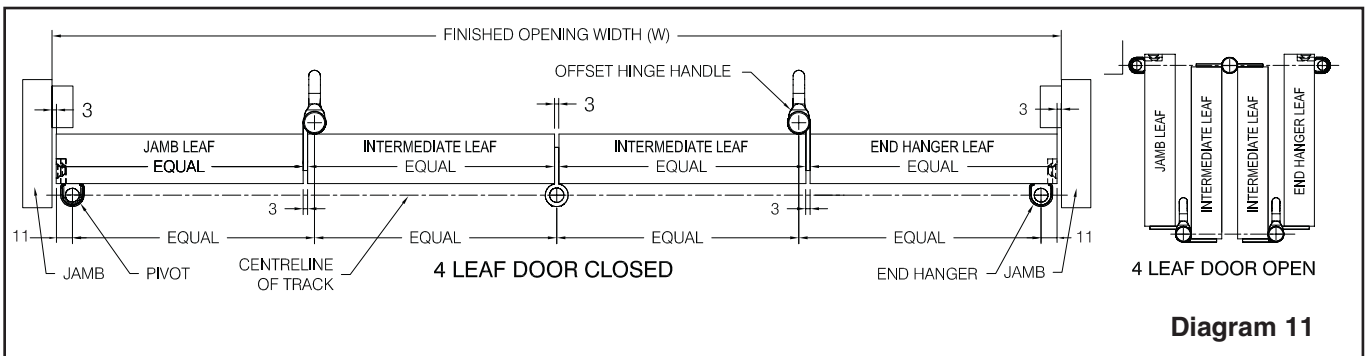
### Door leaf width calculation

1. Decide how many door leaves you want in the opening.
2. Add together all the 3mm clearances required between door leaves and the jambs (there will be one more than the number of door leaves). This is the total clearance figure.
3. Measure the finished opening width (W) and deduct from this the total clearance figure.
4. Divide this new figure (finished opening width minus total clearance) by the number of doors to produce the actual door width. (N.B. all doors with the Securerfold system are the same width).

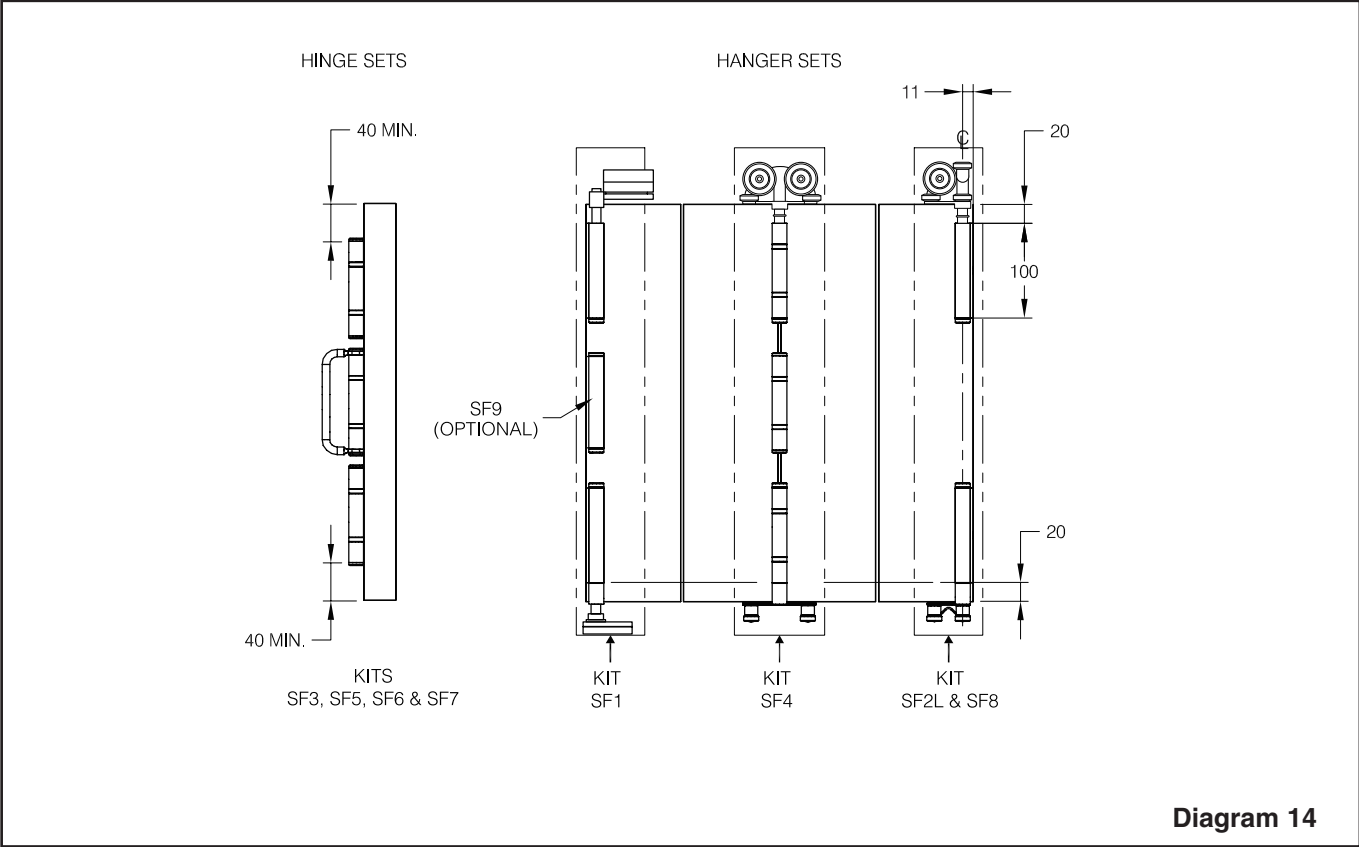
For example: For a 4 door leaf system with a finished opening width of 2345mm the door leaf width would be 2345mm minus (5x3mm) divided by 4 (number of door leaves) = 582.5mm.

### Door leaf height calculation

Leaf height = finished opening height (see diagram 7) minus 66mm.

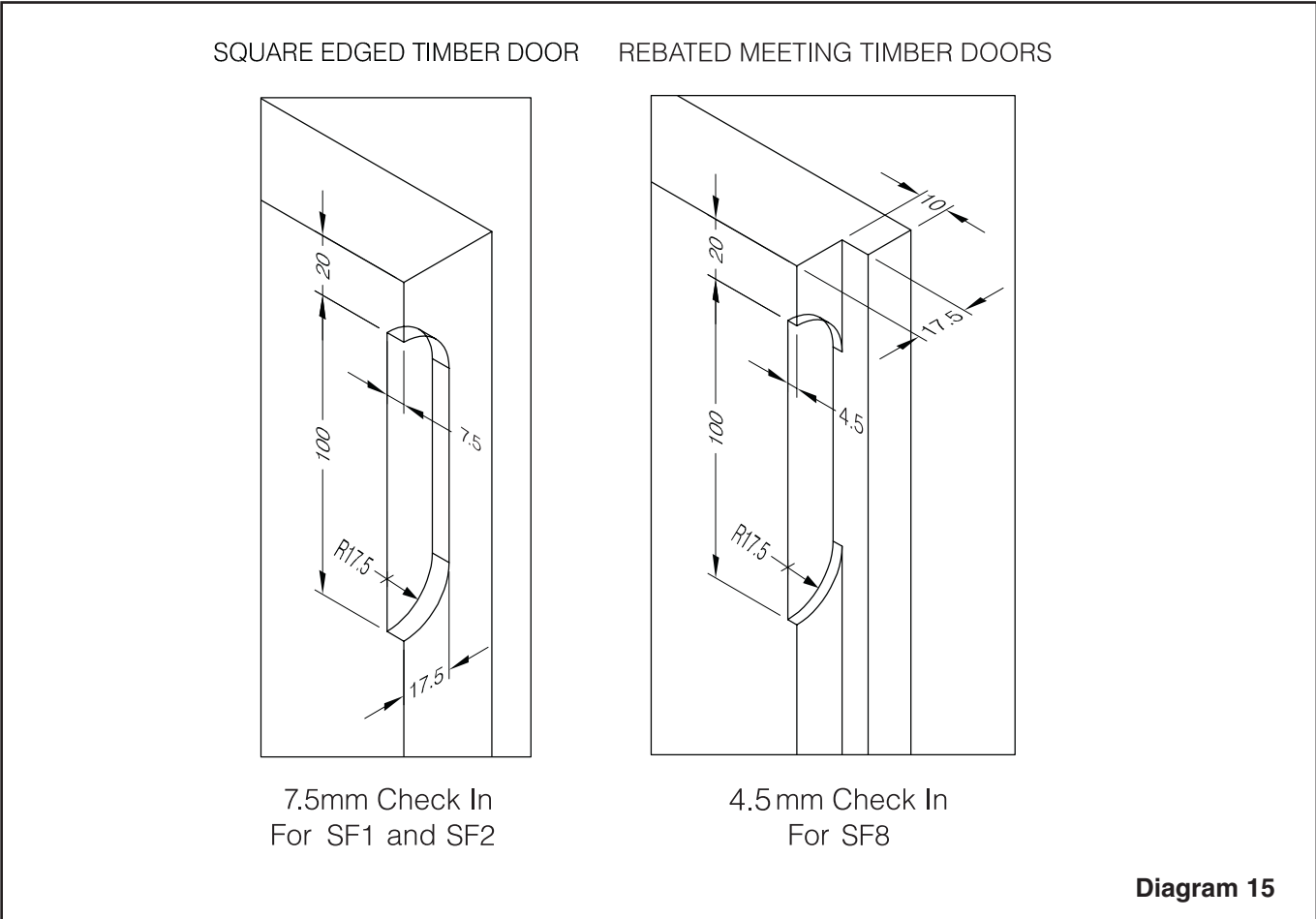


**Door hardware positioning**



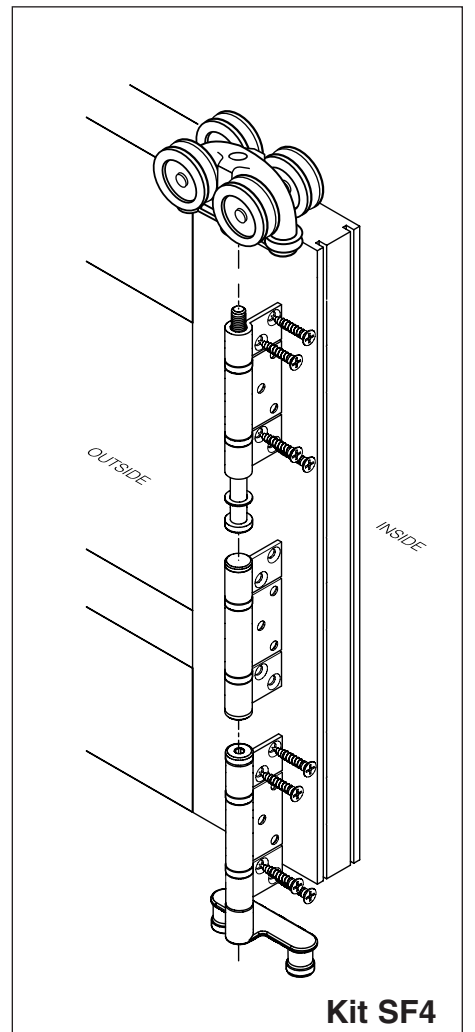
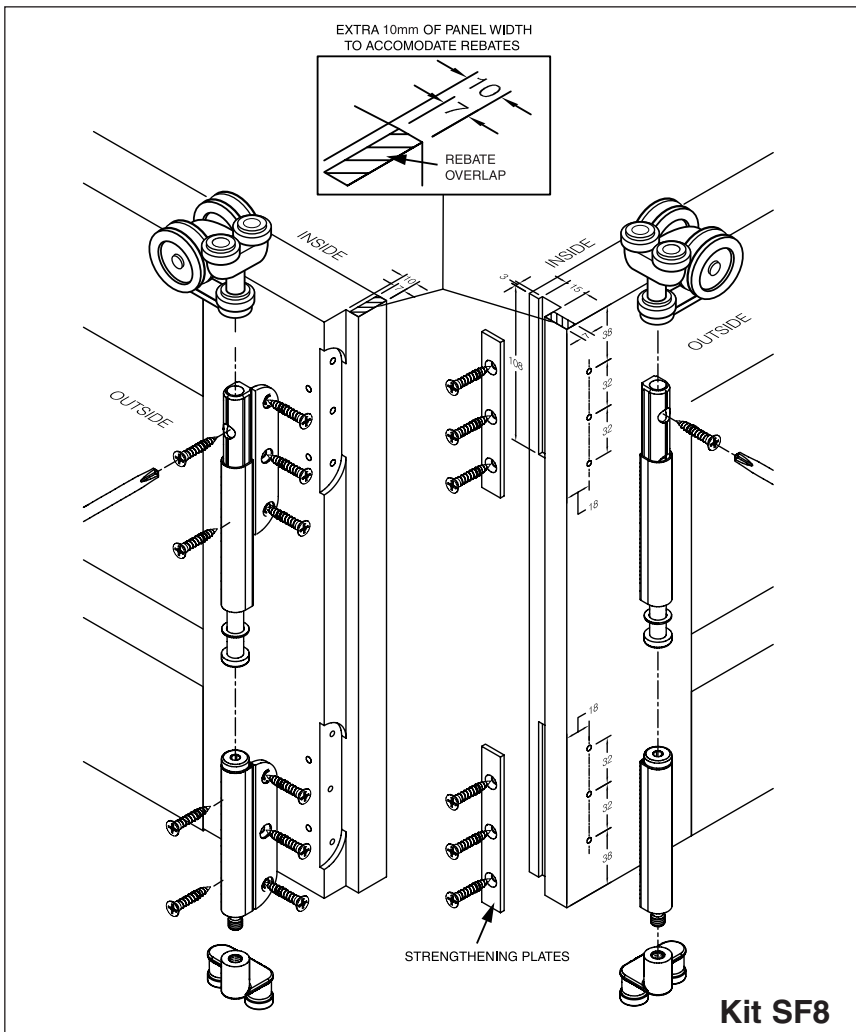
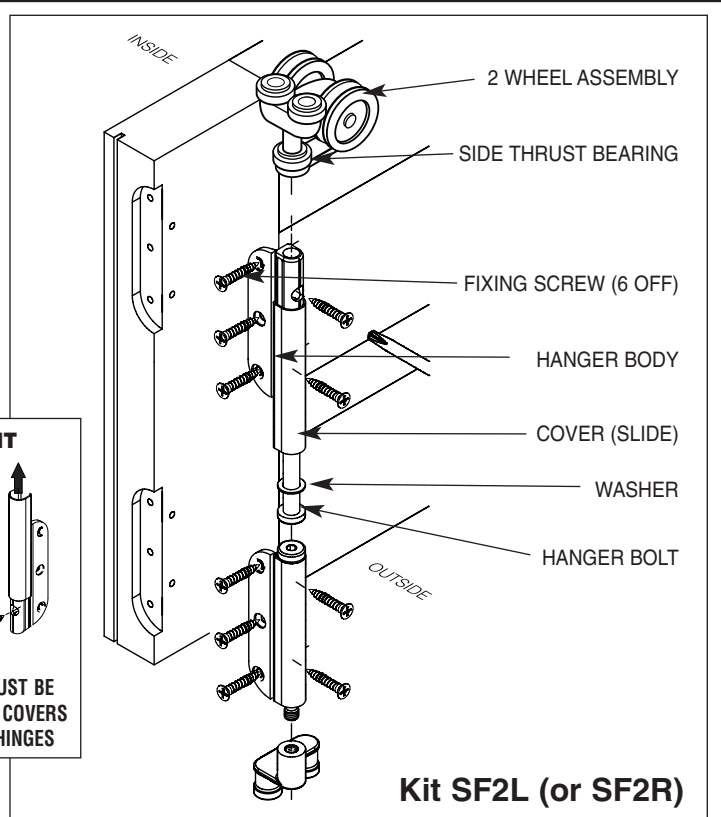
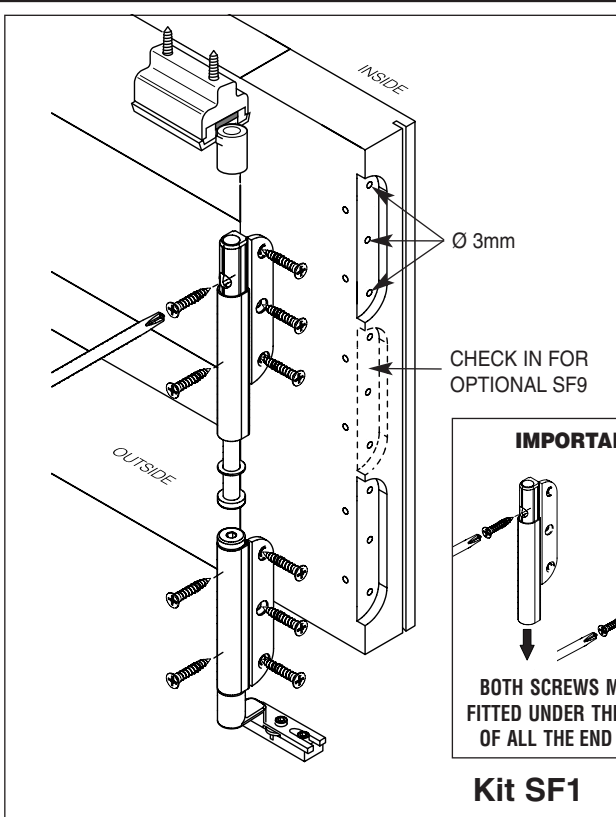
**Diagram 14**

**End door leaf Preparation**



**Diagram 15**

# Door hardware attachment



## INSTALLATION

1. Ensure that you have all the required parts. Unpack the components and identify the parts. Lay the parts on the ground in the same configuration as they will be when installed. It is recommended that a light smear of general purpose grease is applied to all bolts prior to assembly.

2. Cut the track to the required length and pre-drill for fixings in accordance with diagram 17. Please note that the extra fixings are required where the doors stack together.

3. Cut the channel to the required length and fit in the sill. Drill drainage holes (see diagram 1).

4. Remove all the wheel assemblies and pivot block from the hanger and pivot bolts, and disassemble top pivot block assembly.

5. Slide the wheel assemblies and track pivot block into the track in the correct order, orientation, and position and fix the track in position. Reassemble top pivot block assembly (see diagram 18).

6. Remove the bottom pivot assembly and guide roller assembly (see diagram 19). Disassemble the bottom pivot assembly.

7. For installation, assemble leaves in pairs via the hinges. To improve the ease of installation pre-drill pilot holes for all hinge parts. Fit kits SF1, SF7, SF4 and SF9 (optional) to first pair of leaves.

**Please ensure all 5 screws are fixed per end hinge.**

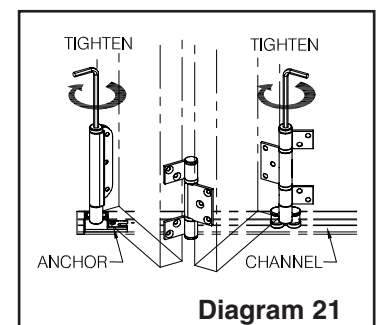
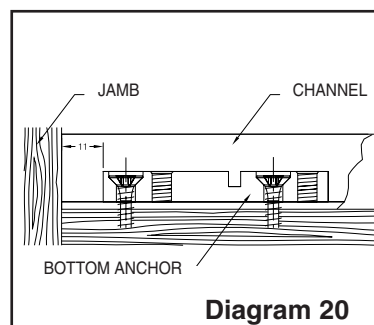
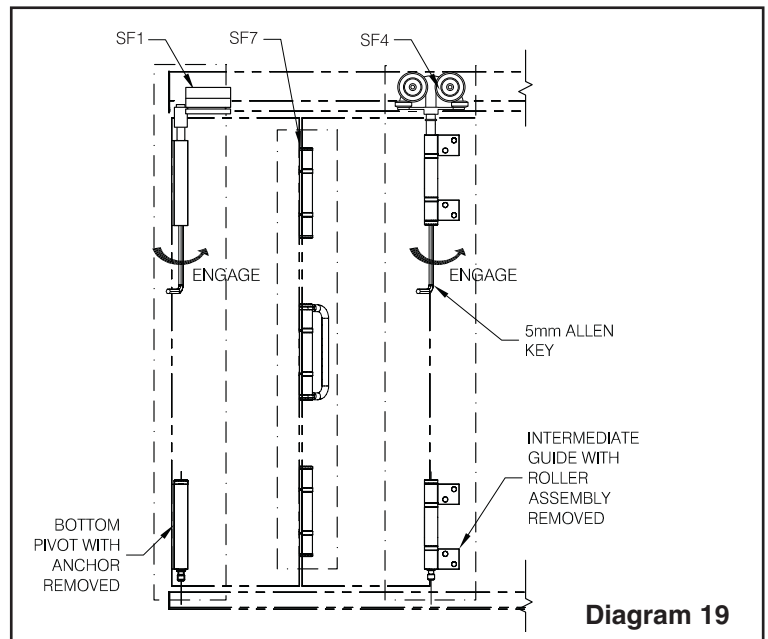
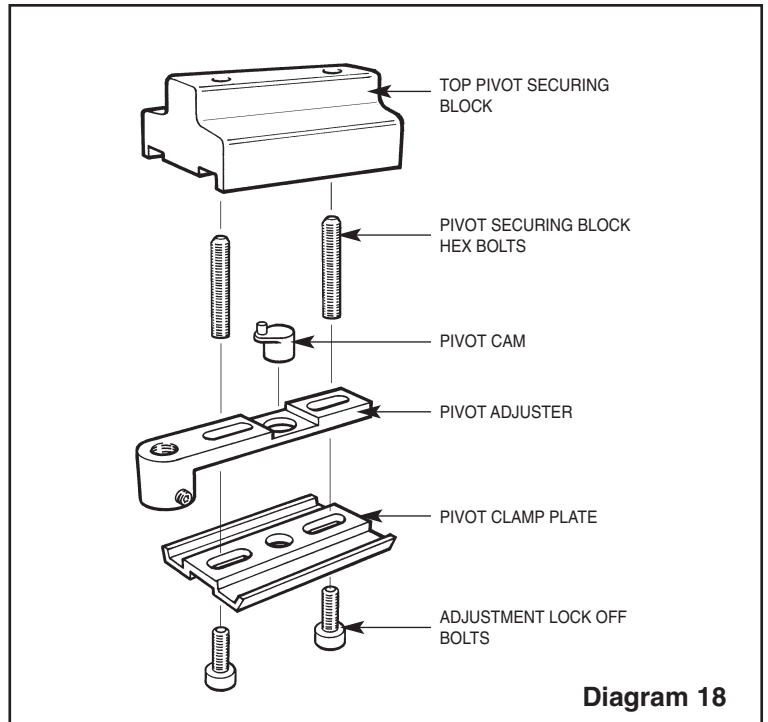
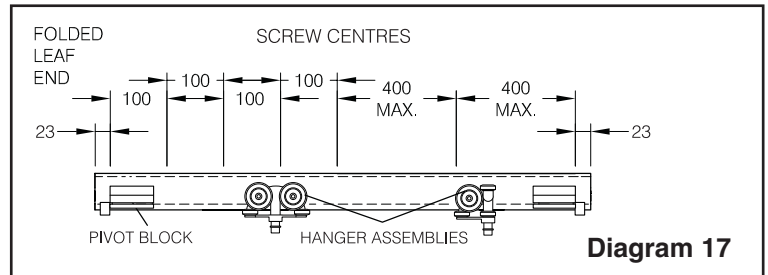
8. Screw the bottom anchor of the bottom pivot assembly to the base of the channel 11mm from the jamb. Please note, the screw nearest the end of the bottom anchor is closest to the jamb (see diagram 20). Reassemble the pivot assembly leaving the clamping screws loose (see diagram 24).

9. Suspend pairs of leaves by engaging top pivot and hanger bolts using 5mm allen key supplied (see top of diagram 19).

10. Attach the bottom pivot and guide assembly to their respective hinges, adjust the bottom pivot side plates position so that it engages with the hinge bolt. Tighten pivot and guide strap bolts (see diagram 21).

11. Lift the next pair of leaves into position and support their weight by screwing the hanger strap bolt into the hanger wheel assembly and fixing the second and third leaves together.

12. Continue this procedure until all leaves are fitted.



## ADJUSTMENT

### Height Adjustment ( $\pm 3\text{mm}$ )

1. Close leaves and adjust the door height to achieve an equal gap between the top of the leaves and the track (a 9mm gap is recommended). (see diagram 22).
2. Once the adjustment is complete use the allen key to tighten the locking hanger grub screw until secure.

### Lateral Adjustment

1. With the unit still in the closed position, slide the set of leaves towards the jamb to obtain the desired gap between the jamb and the pivot door. A gap of 3mm is recommended using the adjustment cam. Once in position tighten the clamp screws. (see diagram 24).
2. Fold the leaves and adjust the bottom side plate using the allen key provided so that the gap between the door and the jamb is the same over the full length of the door.
3. Tighten the two clamping screws to lock the side plate to the bottom anchor.
4. Once the pivot door is in the correct position insert and tighten the locking pivot grub screw from the inside position. (as shown in diagram 23)

## CARE AND MAINTENANCE

To provide years of trouble free operation, it is recommended that the track is kept free from dirt and debris. Periodically replace the general purpose grease on all bolts. To prolong the appearance of the exposed hinge parts, it is recommended they are periodically washed with soap and water. Maintenance is required on all components including stainless steel to validate manufacturers warranty. For further maintenance details please refer to our website, [www.pchenderson.com](http://www.pchenderson.com).

